

# 306E2

Mini Hydraulic Excavator



## Engine

Engine Model	Cat® C2.4 (DI Turbo)
Net Power	34.7 kW (47.2 hp)
Gross Power @ 2,200 rpm	36.5 kW (49.6 hp)

## Weights

Operating Weight	5800 kg
------------------	---------

## Bucket

Standard Bucket Size	0.25 m <sup>3</sup>
----------------------	---------------------

## 306E2 Features

### Increased Performance

*Lower fuel consumption and higher fuel efficiency keeps you working all day.*

*Standard/Power dual mode offers the choice of lower fuel consumption or superior productivity.*

*Smooth new intuitive flow sharing "High Definition Hydraulic" system provides the level of control demanded in any application.*

### High Altitude and Cold Start Capability

*306E2 is equipped with the Cat C2.4 DI Turbo engine with altitude capability to 2500 m and cold start capacity as low as -15 degrees.*

### Stability

*Conventional tail swing design with an extended counterweight provides excellent stability while maximizing lifting.*

### Maintenance

*Superior serviceability with the counterweight positioned low at the back and two big side doors, making all the maintenance points extremely easy to touch from ground level.*



## Contents

Performance .....	4
Undercarriage .....	5
Operator Comfort .....	6
Engine .....	7
Engine and Serviceability .....	8
Specifications .....	10
Standard Equipment .....	13
Optional Equipment .....	14
Notes .....	15



**The new Cat 306E2 Mini Hydraulic Excavator has been designed and built by Caterpillar to deliver exceptional superior performance, productivity, controllability and reliability at lower operating cost. The extremely fast, smooth and responsive hydraulic movement offers greater job accuracy and efficiency. The standard tail swing design incorporates a counterweight that extends further back on the machine to maximize the machine stability for lifting and digging. The 306E2 sets the standard for conventional tail swing excavators in the six-ton size class.**

# Performance

Powerful digging combined with smooth control.



## Hydraulics

Smooth responsive hydraulics give the level of control demanded by the customer in any application, from fine grading and dozing to backfilling.

Powerful bucket and stick digging forces combined with fast cycle times result in world class productivity and performance.

Manual two speed function improves job site maneuverability with precise control by balancing travel speed with the torque needed for turning and traveling on inclines. Dozer blade float function enables easy ground leveling for landscaping and finish grade applications as well as more efficient job site clean-up.

## Stick and Boom

The front structure is designed to provide maximum digging capability using high tensile strength steel. All pins used in the front linkages have thick chrome plating to prevent pin galling and squealing for long pin and stick life. The diameter of each pin is made as large as possible to smoothly distribute the shear and side loads associated with the stick during tough digging jobs. The pin and low maintenance bushing arrangement reduces pin friction, extending the greasing interval.



## Lift Capacity

The new Cat E Series has industry leading lift capacity matched with outstanding stability. This provides the control required to meet the diverse and continually changing needs of the customer.

## Steel Track

Caterpillar designed undercarriage is built for stability and durability. A 400 mm triple grouser track is standard. Lower profiled undercarriage provides better stability and lifting capability. Travel motors with two-speed capability and strong track drives provide high gradeability and turnability for various ground conditions. Split master link and sealed track rollers reduce owning and operating costs. Steel tracks provide optimum stability when lifting over the side.



## Undercarriage

Excellent stability.



### Dozer with Float Function

The dozer function is pilot controlled from inside the cab, providing smooth, proportional operation. The dozer float function is enabled by pushing the lever fully forward into the decent position. Site clean up and backfilling is easier as the operator does not have to adjust the blade height during travel.

### Travel Motor and Swing Motor

New motors provide better performance and reliability.

# Operator Comfort

Simple, easy operation allows the operator to focus on production.



## Operator Station

The redesigned operator environment provides the operator with a larger cab and more ingress and egress room. The intuitive cab layout also features ergonomic joysticks.

## Ease of Operation

Low effort, ergonomically designed pilot hydraulic levers provide full controllability. Maximum travel speed can be selected by the easily accessible switch on right hand side of the console. The integrated monitor reports vehicle information accurately.

## Quiet and Comfortable Operator Station

The spacious cab provides a comfortable working environment for the operator.

- New engine air intake hose routing to lower the noise level inside the operator station
- New cab mounting – viscous cab mounting system
- Low operator and spectator sound levels
- Cab includes heater and air conditioner for maximum comfort in a range of climatic conditions
- Fully adjustable, reclining fabric suspension seat with headrest for greater comfort
- Flat floor allows easy sweep out



## Excellent Visibility

The 306E2 features excellent visibility to the work tool and machine surroundings.

- Assisted front window opens easily
- Removable lower front window
- Front window wiper and washer for a clear view
- Dozer blade is visible from all swing angles for maximum convenience

## Power Mode Switch

Standard/Power dual mode offers the choice of lower fuel consumption or superior productivity by an easy single touch.





## Engine

Clean, quiet, and efficient.

### **Powerful (Efficient DI Turbocharged) Engine and Load Sensing Hydraulics**

The new Cat C2.4 DI efficient 36.5 kW (48.9 hp) engine is matched with a load sensing hydraulic system to provide excellent digging performance and smooth control. Low noise and vibration levels deliver comfortable operation with high altitude capability to 2500 m.

### **Lower Fuel Consumption**

Standard/Power dual mode offers customers the choice to have lower fuel consumption or superior productivity.

### **One Side Maintenance**

The Cat C2.4 DI engine offers superior maintenance convenience with its large steel rear door and two big side doors for easy access to all major components and service points.

# Engine and Serviceability

Superior power with easy access and minimal maintenance requirements keep you working.



## Customer Support – Unmatched Support Makes the Difference

Your Cat dealer is ready to assist you with your purchase decision and everything after.

- Financing packages are flexible to meet your needs
- Unmatched parts availability keeps you working
- Make comparisons of machines, with estimates of component life, preventative maintenance and cost of production
- For more information on Cat products, dealer services and industry solutions, visit [www.cat.com](http://www.cat.com)



### **Excellent Service Access and “One Side Maintenance” Engine**

Fast, easy service with extended service intervals, convenient filter access and user-friendly electronic diagnostics increases productivity and reduces maintenance costs:

- Large steel rear door and two big side doors for easy access to all major components and service points
- The main hydraulic valve and lines are also easily reached through a removable floor plate and side panels
- All grease fittings can be easily reached
- Daily checks and regular service maintenance points accessible from ground level
- Radial seal air filter provides easier maintenance
- Efficient, large fuel filter and water separator with valve for easier maintenance
- Maintenance free Cat batteries are standard
- Low maintenance bushings extend greasing intervals to 500 hours on blade and front linkage joints
- The machine has durable steel body panels all around, offering good resistance to impact damage and helping to maintain the machine’s appearance and value
- S-O-S<sup>SM</sup> oil sampling valve allows easy sampling of the hydraulic fluid for preventative maintenance

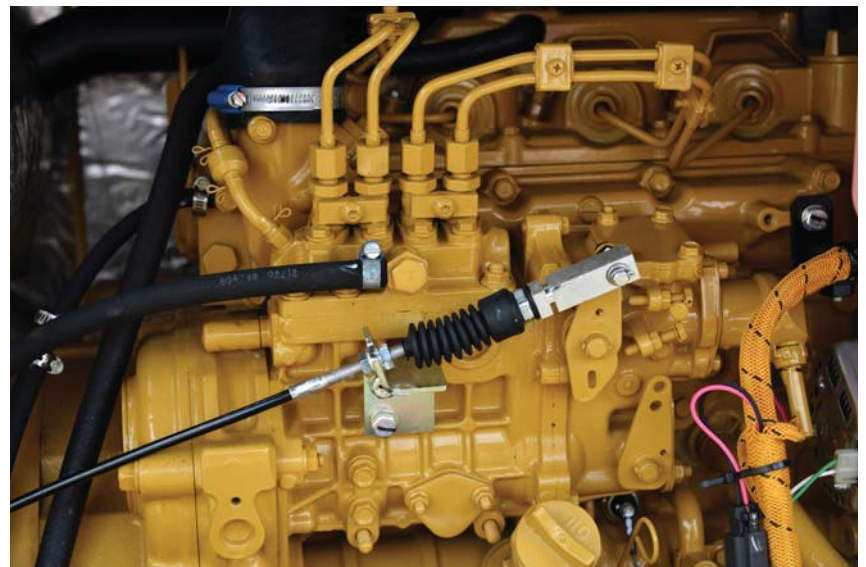

# 306E2 Mini Hydraulic Excavator Specifications

## Engine

Engine Model	Cat C2.4 (DI Turbo)
Net Power	34.7 kW (47.2 hp)
Gross Power @ 2,200 rpm	36.5 kW (49.6 hp)
Bore	87 mm
Stroke	102.4 mm
Displacement	2.4 L
<ul style="list-style-type: none"><li>• Meets China Stage II Nonroad emissions requirements.</li><li>• Net power rating per ISO 9249 and SAE J1349.</li></ul>	

## Weights

Operating Weight	5800 kg
<ul style="list-style-type: none"><li>• Weight includes counterweight, steel track, 0.25 m<sup>3</sup> bucket and operator.</li></ul>	

## Hydraulic System

Digging Forces – Stick (standard)	28 kN
Digging Force – Bucket	39 kN
Main System – Maximum Flow	140 L/min
Maximum Pressure – Implements	25 000 kPa

## Swing System

Machine Swing Speed	10.5 rpm
Swing Torque	14.2 kN·m

## Blade

Width	1950 mm
Height	360 mm

## Service Refill Capacities

Cooling System	8.3 L
Engine Oil	9.5 L
Fuel Tank	78 L
Hydraulic Tank	58 L
Hydraulic System	85 L

## Drive

Travel Speed	2.8/4.3 km/h
Maximum Drawbar Pull	46.4 kN

## Track

Track Shoe Width (standard)	400 mm
Track Length	2440 mm
Number of Shoes (each side)	38
Number of Track Rollers (each side)	5
Number of Carrier Rollers (each side)	1

- Track shoe has four holes for pad shoe adoption.

# 306E2 Mini Hydraulic Excavator Specifications

## Dimensions

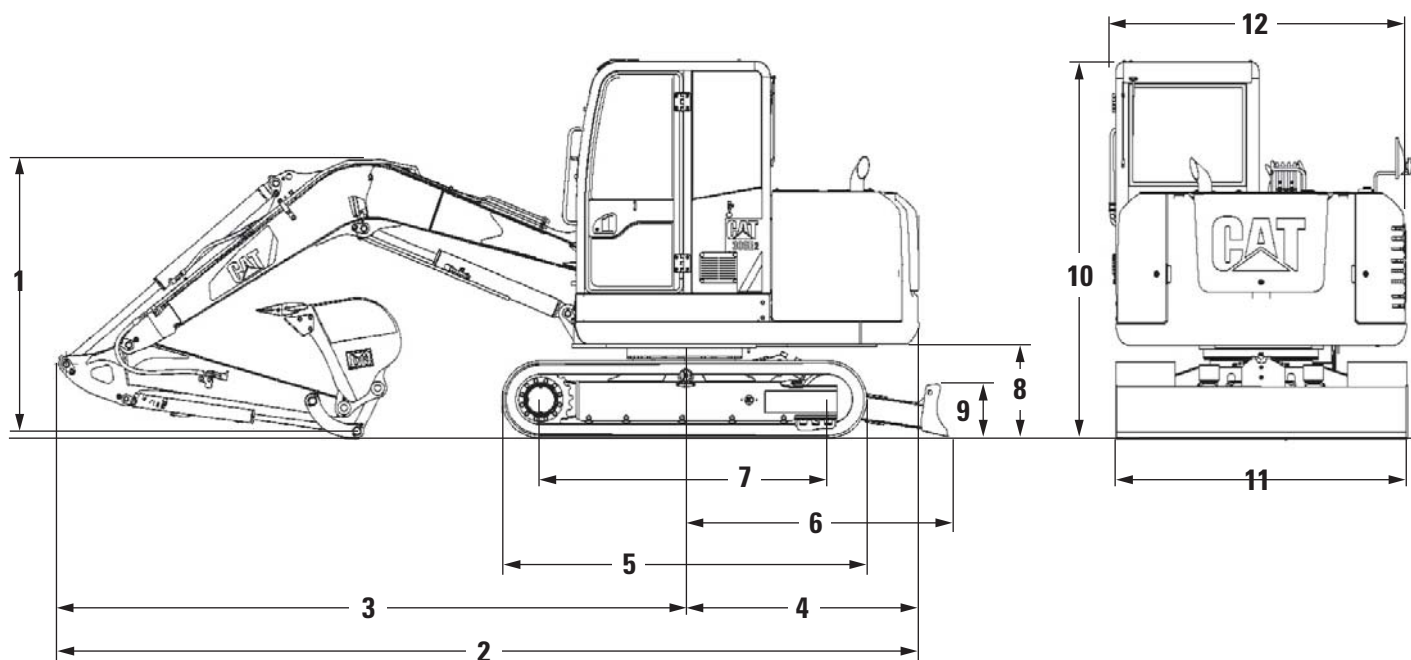

Standard Stick	
1	1878 mm
2	5785 mm
3	4205 mm
4	1580 mm
5	2440 mm
6	1765 mm
7	1920 mm
8	628 mm
9	360 mm
10	2540 mm
11	1950 mm
12	2005 mm

**Note:** All working dimensions are with OSJ bucket.  
Without shoe lug.

# 306E2 Mini Hydraulic Excavator Specifications

## Working Range

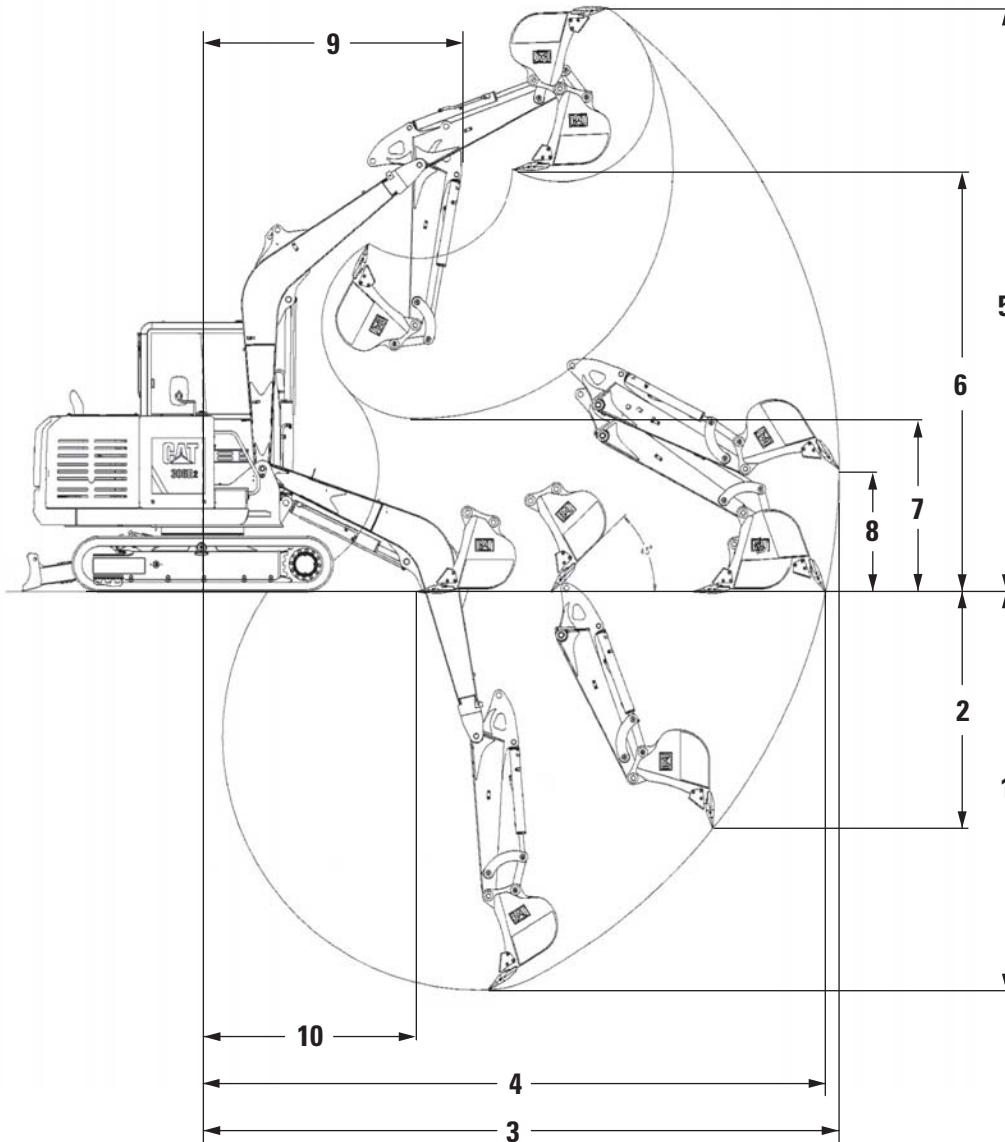

### Standard Stick

<b>1</b>	3870 mm
<b>2</b>	2340 mm
<b>3</b>	6090 mm
<b>4</b>	5970 mm
<b>5</b>	5530 mm
<b>6</b>	3900 mm
<b>7</b>	1470 mm
<b>8</b>	1170 mm
<b>9</b>	2415 mm
<b>10</b>	1905 mm

## Standard Equipment

Standard equipment may vary. Consult your Cat dealer for details.

- Cat C2.4 DI diesel engine with mechanical governor
- One touch low idle
- Two speed travel with manual shift
- Cat one key security system
- Door locks and cap locks
- Signaling/warning horn
- Product Link™
- Muffler with cover
- Radial seal air filter, double element
- Stacked cooling package
- Auxiliary hydraulic valve (one way/two way)
- Straight line travel
- Accumulator
- Cab:
  - Openable front windshield with assist device
  - Removable lower windshield with in cab storage bracket
  - Windshield wiper and washer
  - Interior lighting
  - Coat hook
  - Ashtray
  - Radio mounting (meet DIN size)
  - Two stereo speakers
  - Antenna
  - Cup holder
  - Storage pocket
  - Mounting for front and top guard (mounting boss)
- Monitor:
  - Instrument panel and gauge
  - Warning information and machine condition
- Hour meter
- Retractable seat belt (50 mm width)
- Hydraulic activation control lever (lock out) for all controls
- Two travel control hand levers
- Capability to install one additional pedal for auxiliary hydraulic control
- 400 mm triple grouser track shoes with holes (for rubber pad)
- 1950 mm blade with cutting edge
- Towing eye on base frame
- Rearview mirror, mounted on right hand side of upper frame
- Lighting – cab

# 306E2 Optional Equipment

## Optional Equipment

Optional equipment may vary. Consult your Cat dealer for details.

- Controls, auxiliary – auxiliary hydraulic lines from main auxiliary valve to boom foot plus auxiliary control pedal, auxiliary hydraulic lines from boom foot to stick, stop valves
- Travel alarm
- Heavy duty swivel guard
- Cab front guard
- Drain group – oil pan
- Heater, water jacket
- Manufacturing film – plate for year of manufacture for export machines



For more complete information on Cat products, dealer services, and industry solutions, visit us on the web at [www.cat.com](http://www.cat.com)

© 2015 Caterpillar  
All rights reserved

Materials and specifications are subject to change without notice. Featured machines in photos may include additional equipment. See your Cat dealer for available options.

CAT, CATERPILLAR, SAFETY.CAT.COM, their respective logos, "Caterpillar Yellow" and the "Power Edge" trade dress, as well as corporate and product identity used herein, are trademarks of Caterpillar and may not be used without permission.

AEHQ7367-02 (12-2015)  
Replaces AEHQ7367-01  
(GN1)

